



GreenLine

- Classic Pump
- High Pressure Pumps
- Flush Pumps
- Propeller Mix Pumps

GreenLine E-Series Pumps

The introduction of the E-series pumps brings together a new level of quality to the industry. DariTech has designed the E-series for easy installation and field service. Built with heavy galvanized tubes and mounting hardware, along with interchangeable components on all pumps and agitators.





**Mix Pump
15hp - 60 hp**

- SS fittings on top and bottom of discharge tube
- Full 6" discharge pipe made from thick, heavy duty galvanized tubing
- 4" Submerged inlet fitting
- 6" pump discharge reduces plugging by 95%



- Motor mounting bracket is a pivot design and always stays square to the pump which makes belt tensioning quick and simple

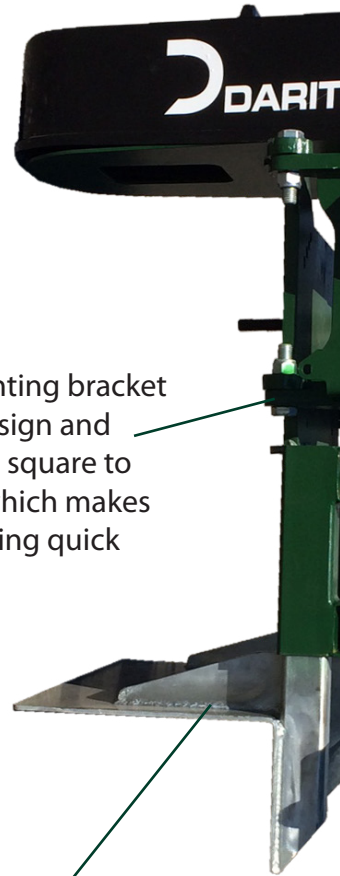

- Galvanized mounting bracket with easy set on bracket
- No bolts required

- Easy knife adjustment



- Adjustable legs

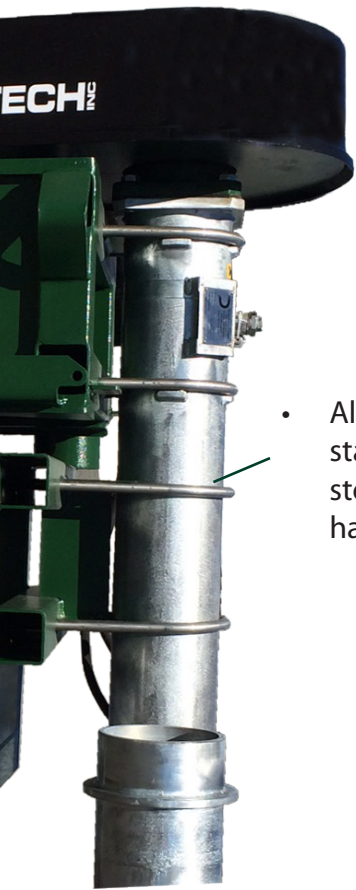

- All stainless steel hardware



**Classic Pump
7.5 hp - 50 hp**

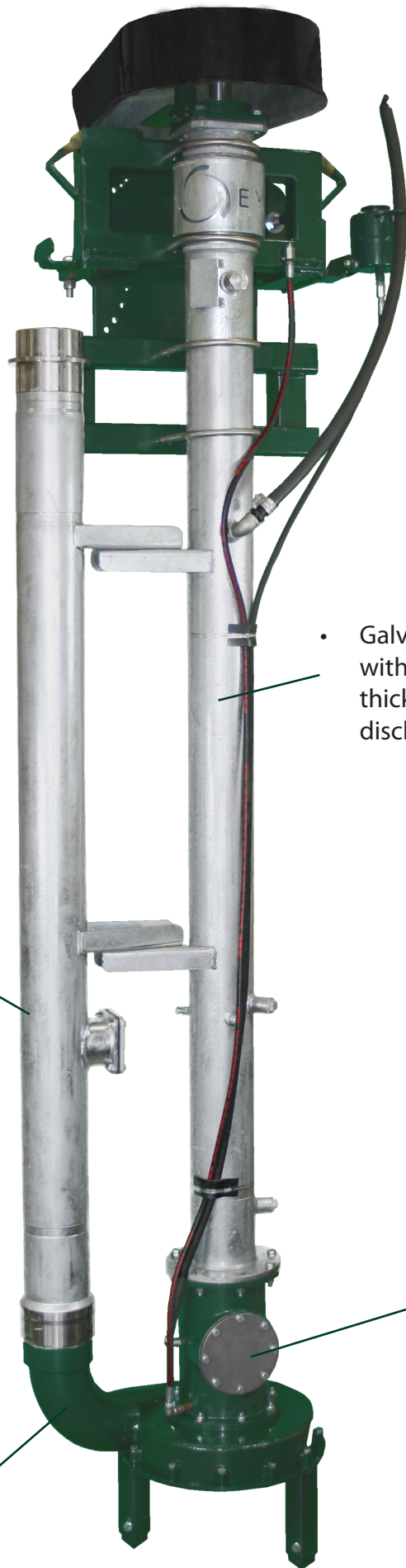

- Galvanized construction with heavy wall thickness on drive and discharge tubes

- Interchangeable discharge for any pump with or without mix prop

- Heavy duty bearing block
- Same length as mix pump allows for easy change out

- Optional full 6" agitation diverter available

- Available in standard pump, flush pump and high pressure pump configurations

- 6" pump discharge reduces plugging by 95%

Our pump line offers a broad selection of innovative features for demanding dairy applications.

DT Mix Agitator

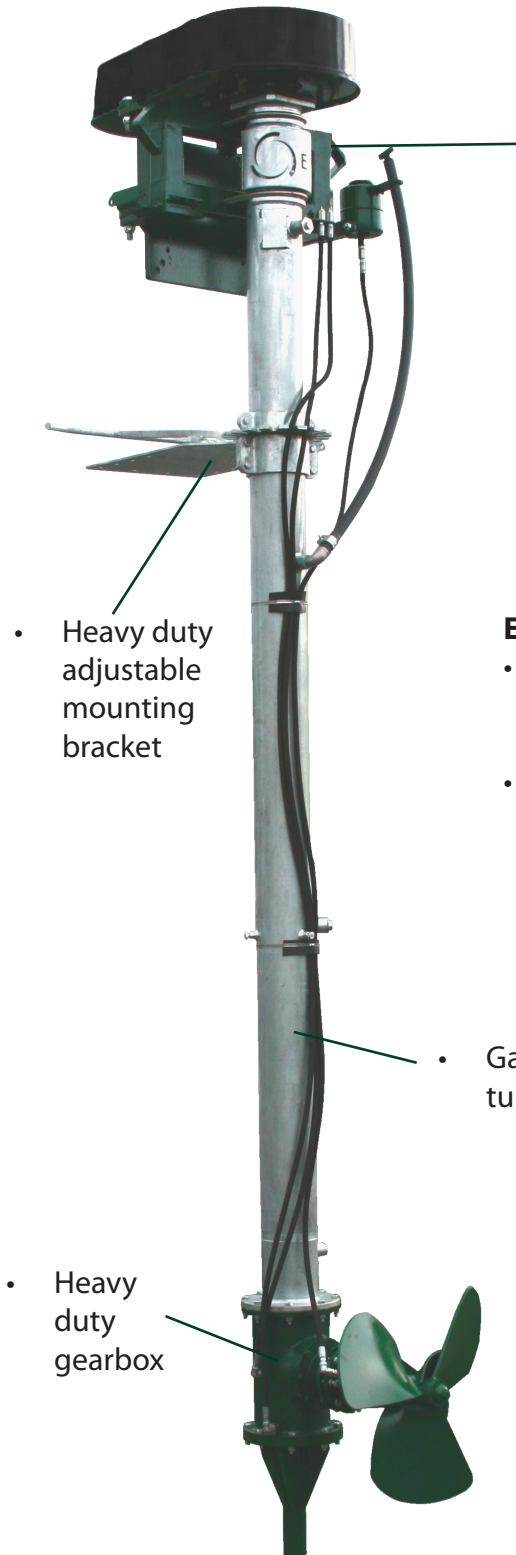

- Easy adjust hinged motor mounting bracket



Electronic Change Over Valve

- Gives complete control of pumping speed from controller
- Less service and wear items

- Heavy duty adjustable mounting bracket

- Galvanized tubing

- Heavy duty gearbox

DT 8600 Piston Pump HD Model 7.5 hp

